

DESCRIZIONE - DESCRIPTION

Valvola a sfera a passaggio standard M/M
c//premistoppa, leva in acciaio ST, e in alluminio T.

*Standard way ball valve MXM with stuffing box
with flat steel lever and aluminium T handle.*



1230T



1230ST

CARATTERISTICHE - FEATURES

- corpo, manicotto e sfera, in ottone CW617N.
- Premistoppa e asta in ottone CW614N
- sfera lavorata con utensile in diamante, cromata.
- sedi in P.T.F.E. vergine dimensionate con angolo di tenuta di 7° min.
- guarnizione tenuta asta: anello PTFE+o-r NBR
- leva di comando in acciaio plastificato ST, alluminio T
- finitura superficiale nichelata filettature gialle.
- filettature ISO 228/1
- PN 25: TEMP. : -20°C ÷ 120°C
- *brass CW617N body, bonnet and ball.*
- *brass CW614N stuffing box and stem*
- *ball ground by diamond-tipped tool, chromium plated.*
- *virgin P.T.F.E. seats with 7° min. tightness angle.*
- *stem tightness: PTFE ring.+ o-ring in NBR rubber.*
- *Steel lever with red plastic coating ST, aluminium T*
- *Nickel plated finishing with yellow threads.*
- *threading to ISO 228/1.*
- *PN 25: TEMP. : -20°C ÷ 120°C*

DIMENSIONI PRINCIPALI - LEADING DIMENSIONS

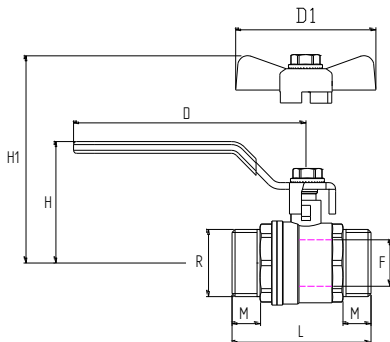

R	3/8	1/2	3/4	1	1 1/4	1 1/2	2
D	85	85	85	114	114	142	142
D1	54	54	54	70	70		
H	41	44	47	60	68	75	80
H1	31	34	39	49	57		
L	49	52.5	58.5	69.5	80	93.5	109
M	10	11	12	14.5	15.5	18	20
F	10	14	18	23	29	34	44

PRESSIONI DI ESERCIZIO A MAX 80°C - WORKING PREASSURES AT 80°C

PN 40								p.s.i. 600
PN 30								p.s.i. 435
PN 25	*	*	*	*	*	*	*	p.s.i. 350
PN 20								p.s.i. 300
	3/8"	1/2"	3/4"	1"	1 1/4"	1 1/2"	2"	

PERDITE DI CARICO - PRESSURE DROPS

R"	3/8	1/2	3/4	1	1 1/4	1 1/2	2
Kv	9	14	25.5	55.5	88	150	248

$$\Delta P [\text{mm H}_2\text{O}] = 10.000 \times \left[\frac{G [\text{mc/h}]}{Kv} \right]^2$$